

ISRO

**Previous Year Paper
Refrigeration and Air
Conditioning 2013**

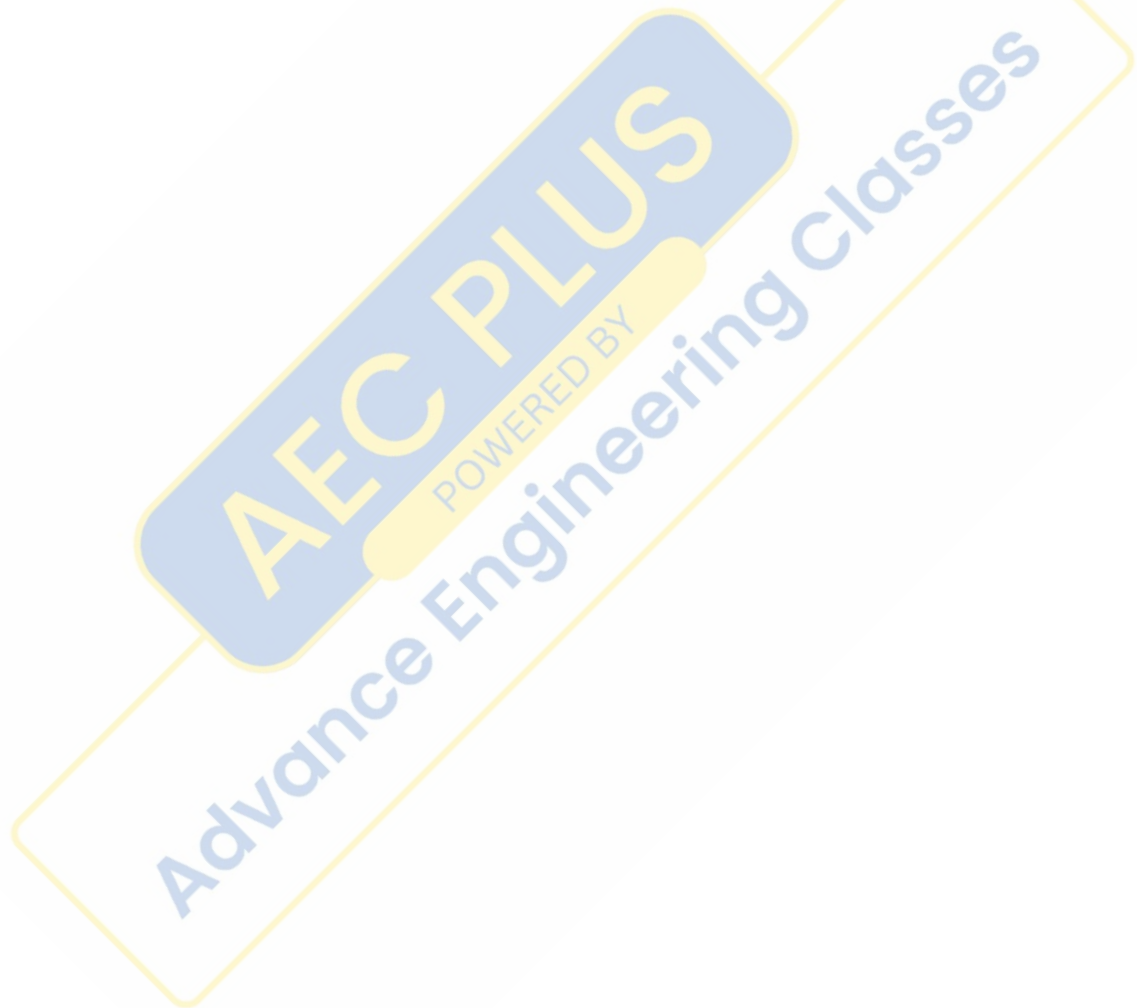
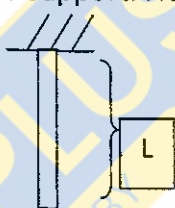

1. The resultant of two equal forces P making an angle θ , is given by:
- (a) $2P \sin(\theta/2)$ (b) $2P \tan(\theta/2)$ (c) $2P \cot(\theta/2)$ (d) $2P \cos(\theta/2)$
2. A body weighs 98N on a spring balance on the north pole. The same body is shifted to the equator, the weight of the body at the equator on the same scale is: (Assume $g=9.8 \text{ m/sec}^2$ and radius of the earth=6400 km)
- (a) 97.45N (b) 98.66 N
(c) 97.66 N (d) 98.22N
3. A uniform heavy rod of weight W , cross-sectional area A and length L and having Young's Modulus E is hanging vertically from a fixed support. Neglecting lateral contraction, the elongation of the rod is given by:
- 
- (a) $5WL/3AE$ (b) $48WL/AE$ (c) $WL/2AE$ (d) $WL/(548AE)$
4. Two bars B_1 and B_2 of different materials and the same size are subjected to the same tensile force. If the bars have unit elongation in the ratio of 3:7 respectively, then the ratio of modulus of elasticity of the two bars B_1 and B_2 will be:
- (a) 3:7 (b) 7:3 (c) 3:4 (d) 4:3
5. The pressure at a point 6 m below the free surface of water is:
- (a) 58.86 kPa (b) 58.86 Pa (c) 58.86 bar (d) 58.86 MPa
6. A uniform body of 4 m long, 1 m wide and 1 m deep floats in water. If the depth of immersion is 0.6 m, then the weight of the body is:
- (a) 20.54 kN (b) 23.54 kN (c) 35.54 kN (d) 45.54 kN

7. A jet of water discharging from a 6 cm diameter orifice has a diameter of 40 mm at its vena contracta. The coefficient of contraction is:
- (a) 0.36 (b) 0.54 (c) 0.21 (d) 0.44
8. A Pelton wheel develops 2000 kW under a head of 100 metres while running at 200 r.p.m. and discharging 3000 litres of water per second. The unit discharge of the wheel is:
- (a) $0.8 \text{ m}^3/\text{sec}$ (b) $0.3 \text{ m}^3/\text{sec}$ (c) $0.5 \text{ m}^3/\text{sec}$ (d) $0.6 \text{ m}^3/\text{sec}$
9. What Drag force is exerted at sea level by a 3.5m braking Parachute when the speed is 20 m/s $C_d = 1.20$ and this remains constant, $\rho_{\text{air}} (\text{sea level}) = 1.225 \text{ kg/m}^3$
- (a) 2828.6 N (c) 282.86 N
(b) 28.28 N (d) 2.828 N
10. To convert volumetric analysis to gravimetric analysis, the relative volume of each constituent of the flue gases is:
- (a) divided by its molecular weight (b) multiplied by its density
(c) multiplied by its specific weight (d) multiplied by its molecular weight
11. A perfect gas at 27°C is heated at constant pressure till its volume is double. The final temperature is:
- (a) 237°C (b) 327°C (c) 208°C (d) 654°C
12. 1 m^3 of air at a pressure of 10 kg/cm^2 is allowed to expand freely to a volume of 10 m^3 . The work done will be:
- (a) Zero (b) -ve (c) +ve (d) 10^5 kg m
13. One reversible heat engine operates between 1400 K and $T_2 \text{ K}$ and another reversible heat engine operates between $T_2 \text{ K}$ and 600 K . If both the engines have the same heat input and output, then temperature T_2 is equal to:
- (a) 616.85 K (b) 1000.33 K (c) 916.52 K (d) 816.55 K
14. Carnot cycle consists of:
- (a) two constant volume and two isentropic processes
(b) two constant pressure and two isentropic processes
(c) one constant volume, one constant pressure and two isentropic processes
(d) two isothermal and two isentropic process

15. The operating temperature of a cold storage is -4°C . The heat leakage from the surrounding is 30kW for the ambient temperature of 35°C . The actual C.O.P. of refrigeration plant used is one-fifth that of ideal plant working between the same temperatures. The power required to drive the plant is:
- (a) 22.86 kW (b) 19.45 kW (c) 20.56 kW (d) 21.74 kW
16. The essential constituent of a hardened steel is:
- (a) austenite (b) pearlite (c) martensite (d) troostite
17. In a vibrating system, if the actual damping coefficient is 50 N/m/s and critical damping coefficient is 500 N/m/s , then logarithmic decrement is equal to:
- (a) 0.21 (b) 0.45 (c) 0.63 (d) 0.87
18. A block of mass 1.2 kg moving at a speed of 20 cm/s collides head on with a similar block kept at rest, the coefficient of restitution is $3/5$, the loss of kinetic energy during the collision is:
- (a) $6.7 \times 10^{-3}\text{ joule}$ (b) $7.7 \times 10^{-3}\text{ joule}$ (c) $8.7 \times 10^{-3}\text{ joule}$ (d) $17.7 \times 10^{-3}\text{ joule}$
19. Stage efficiency of a turbine is equal to:
- (a) $\frac{\text{Work done on blades}}{\text{Total energy supplied}}$ (b) $\frac{\text{Work done on blades}}{\text{Energy supplied per stage}}$
- (c) $\frac{\text{Energy supplied per stage}}{\text{Work done on blades}}$ (d) $\frac{\text{Total energy supplied}}{\text{Work done on blades}}$
20. A pendulum bob has a speed of 3 m/s while passing through its lowest position, the speed of the bob when it makes an angle of 60° with the vertical is: (Assume $g = 10\text{ m/sec}^2$ and Length of pendulum is 0.5 m) :
- (a) 1 m/s (b) 1.5 m/s (c) 1.75 (d) 2.0 m/s

21. In a thin cylindrical shell subjected to an internal pressure p , the ratio of longitudinal stress to the hoop stress is:
- (a) $1/2$ (b) 4.0 (c) $1/4$ (d) 2.0
22. A hot plate transfers heat with a heat flux of 8000 W/m^2 into the ambient air at 25°C . If the surface of the hot plate is maintained at 125°C , calculate the heat transfer coefficient for the convection between the plate and the air:
- (a) $75 \text{ W/m}^2\text{-K}$ (b) $80 \text{ W/m}^2\text{-K}$
(c) $70 \text{ W/m}^2\text{-K}$ (d) $60 \text{ W/m}^2\text{-K}$
23. Water at 50°C flows over a hot plate maintained at temperature 150°C . The plate has a width of 50 cm and length of 100 cm. If the heat transfer coefficient between the water and the plate is $2100 \text{ W/m}^2\text{-K}$, the thermal resistance of convection is:
- (a) $7.52 \times 10^{-4} \text{ K/W}$ (b) $10.52 \times 10^{-4} \text{ K/W}$
(c) $8.52 \times 10^{-4} \text{ K/W}$ (d) $9.52 \times 10^{-4} \text{ K/W}$
24. An Aluminum sphere dipped into water at 10 degree centigrade, if temperature is increased, the force of buoyancy will:
- (a) increase (b) decrease
(c) remain constant (d) increase or decrease depending on the radius of the sphere
25. According to Lami's theorem:
- (a) the three forces must be equal.
(b) the three forces must be at 120° to each other.
(c) the three forces must be in equilibrium
(d) if the three forces acting at a point are in equilibrium, then each force is proportional to the 'sine' of the angle between the other two.
26. When a body of mass moment of inertia I (about a given axis) is rotated about that axis with an angular velocity ω , then the kinetic energy of rotation is:
- (a) $I\omega^2$ (b) $0.5 I\omega$ (c) $0.5 I\omega^2$ (d) $I\omega$

27. In a boiler, feed water supplied per hour is 225 kg while coal fired per hour is 25 kg. The net enthalpy rise per kg of water is 150 kJ. If the calorific value of the coal is 2050 kJ/kg, then the boiler efficiency will be
- (a) 75% (b) 45% (c) 66% (d) 55%
28. The metacentric height of a ship is 0.5 m and the radius of gyration is 6 m. The time of rolling of a ship is:
- (a) 30.01s (b) 17.01s (c) 15.01s (d) 16.01s
29. For an irrotational flow the equation $\frac{\partial^2 \Phi}{\partial x^2} + \frac{\partial^2 \Phi}{\partial y^2}$ is known as ,
- (a) Bernoulli's equation
(b) Cauchy Riemann's equation
(c) Euler's equation
(d) Laplace equation
30. A Pelton Wheel develops 2500 kW under a head of 150 metres while running at 200 r.p.m. and discharging 200 litres of water per second. The unit power of the wheel is:
- (a) 0.63 kW (b) 0.36 kW (c) 1.36 kW (d) 1.63 kW
31. An Iron rod and a Copper rod lies side by side, as the temperature is changed, the difference in the length of the rods remains constant value of 10 cm. The lengths of Iron and Copper rods at zero degree centigrade shall be ----- . (coefficient of Linear expansion of Iron = 1.1×10^{-5} per degree centigrade and coefficient of Linear expansion of Cu = 1.7×10^{-5} per degree centigrade)
- (a) 18.3 cm and 8.3 cm (b) 28.3 cm and 18.3 cm
(c) 38.3cm and 28.3cm (d) 48.3 cm and 38.3 cm
32. The specific speed of a turbine is given by the equation:
- (a) $\frac{N\sqrt{P}}{H^2}$ (b) $\frac{N\sqrt{P}}{H^{3/2}}$ (c) $\frac{N\sqrt{P}}{H^{5/4}}$ (d) $\frac{N\sqrt{P}}{H^3}$
33. A furnace is made of a red brick wall of thickness 0.6 m and conductivity 0.8 W/m K . For the same heat loss and temperature drop, this can be replaced by diatomite earth of conductivity 0.16 W/m K and thickness of -----
- (a) 0.55m (b) 0.12m (c) 1.25m (d) 0.50m

34. An elevator weighing 500 kg is to be lifted up at a constant velocity of 0.20 m/s. The minimum horse power of the motor is: (assume $g = 9.8 \text{ m/sec}^2$)
- (a) 2.2hp (b) 2 hp (c) 1.5 hp (d) 1.3 hp
35. An electric cable of aluminium conductor ($k=230\text{W/mK}$) is to be insulated with rubber ($k=0.18\text{W/m K}$). The cable is to be located in air ($h=6\text{W/m}^2$). The critical thickness of insulation will be:
- (a) 40 mm (b) 10 mm (c) 30 mm (d) 50 mm
36. A hot fluid enters the counter flow heat exchanger at 120°C and leaves at 80°C . A cold fluid enters the heat exchanger at 60°C . The mean temperature difference between the two fluids is (Assume the values of fluid flow rates and specific heats in such a manner that the heat capacities of the two fluids are equal)
- (a) 15°C (b) 35°C (c) 40°C (d) 20°C
37. In a psychrometric process, the sensible heat added is 40 kJ/s and the latent heat added is 30 kJ/s. The sensible heat factor for the process will be:
- (a) 0.3 (b) 0.2 (c) 0.57 (d) 1.5
38. When two refrigerants are mixed in the proper proportions, the mixture forms a third refrigerant called:
- (a) synthetic refrigerant (b) refrigerant mixture
(c) high pressure refrigerant (d) an azeotrope
39. A fixed gear having 300 teeth is in mesh with another gear having 60 teeth. The two gears are connected by an arm. The numbers of turns made by the smaller gear for one revolution of arm about the centre of bigger gear is:
- (a) 2 (b) 6 (c) 4 (d) 5
40. Nusselt number is the ratio of
- (a) Convective and Conductive resistances
(b) Conductive and Convective resistances
(c) Wall heat transfer rate to mass heat flow rate
(d) Kinetic viscosity to thermal diffusivity

41. A composite slab has two layers of different materials with thermal conductivities k_1 and k_2 . If each layer has the same thickness, then the equivalent thermal conductivity of the slab will be

- (a) $\frac{2k_1 k_2}{k_1 + k_2}$ (b) $\frac{k_1 + k_2}{k_1 k_2}$ (c) $k_1 k_2$ (d) $k_1 + k_2$

42. The period of the function $\cos 3x + \sin 6x$ is:

- (a) $\pi/3$ (b) $2\pi/3$ (c) π (d) 2π

43. If $Y = (2^x - 1)/X^{1/2}$ then $\lim_{x \rightarrow 0} Y$ is:

- (a) $\log 2$ (b) $2\log 2$ (c) Zero (d) None of these

44. Degree and Order of the following differential equation are:

$$\sqrt{\{1 + (dy/dx)^2\}^3} = [d^2y/dx^2]$$

- (a) 6, 2 (b) 2, 6 (c) 2, 2 (d) 6, 3

45. The straight line perpendicular to the line $-2x + 3y + 4 = 0$ is:

- (a) $3x + 2y - 4 = 0$ (b) $3x - 2y + 4 = 0$ (c) $-3x + 2y + 7 = 0$ (d) $3x - 2y - 7 = 0$

46. The maximum value of $f(x) = (\log x) / (x)$ is $1/e$ at:

- (a) $x=1$ (b) $x=e$ (c) $x=1/e$ (d) None of these

47. If $y = \sec^{-1} [(x+1)/(x-1)] + \sin^{-1} [(x-1)/(x+1)]$ then (dy/dx) is equal to:

- (a) 0 (b) $\pi/2$ (c) 1 (d) None of these

48. A small disc shaped earth Satellite, 1 m in diameter circles the earth at a distance of 300 km from the surface. The flat surface of the disc (with emissivity 0.3 and temperature -18°C) is oriented tangential to the earth's surface with view factor of 0.91. Average Earth temperature is $\sim 27^\circ\text{C}$ while surrounding of satellite is 0 K. Net rate at which energy is leaving satellite is

- (a) 0.003 W (b) 14.5 W (c) -42.0 W (d) 42.0 W

49. Consider the following two processes:

(A). A heat source at 1200K loses 2500kJ of heat to sink at 800K

(B). A heat source at 800K loses 2000kJ of heat to sink at 500K

Which of the following statements is TRUE?

- (a) Process I is more irreversible than Process II
- (b) Process II is more irreversible than Process I
- (c) Irreversibility associated in both the processes is equal
- (d) Both the processes are reversible

50. A fin has 5mm diameter and 100mm length. The thermal conductivity of fin material is $400\text{Wm}^{-1}\text{K}^{-1}$. One end of the fin is maintained at 130°C and its remaining surface is exposed to ambient air at 30°C . if the convective heat transfer coefficient is $40\text{Wm}^{-2}\text{K}^{-1}$, the heat loss (in W) from the fin is

- (a) 0.08
- (b) 5.0
- (c) 7.0
- (d) 7.8

51. A solar energy based heat engine which receives 80 kJ of heat at 100°C and rejects 70 kJ of heat to the ambient at 30°C is to be designed. The thermal efficiency of the heat engine is

- (a) 70%
- (b) 1.88%
- (c) 12.5%
- (d) indeterminate

52. The temperature variation under steady heat conduction across a composite slab of two materials with thermal conductivities K_1 and K_2 is shown in Figure. Then, which one of the following statements holds?

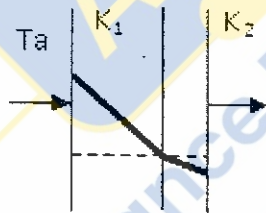

- (a) $K_1 > K_2$
- (b) $K_1 = K_2$
- (c) $K_1 = 0$
- (d) $K_1 < K_2$

53. What is the value of the view factor for two inclined flats having common edge of equal width, and with an angle of 20° degrees?

- (a) 0.83
- (b) 1.17
- (c) 0.66
- (d) 1.34

54. A 2 kW, 40 litre water heater is switched on for 20 minutes. The heat capacity C_p for water is 4.2 kJ/kg-K. Assuming all the electrical energy has gone into heating the water, increase of the water temperature in degree centigrade is

- (a) 2.7 (b) 4.0 (c) 14.3 (d) 25.25

55. Heat is being transferred by convection from water at 48°C to a glass plate whose surface that is exposed to the water is at 40°C. The thermal conductivity of water is 0.6 W/m-K and the thermal conductivity of glass is 1.2 W/m-K. The spatial gradient of temperature in the water at the water-glass interface is $dT/dy=1 \times 10^4$ K/m.

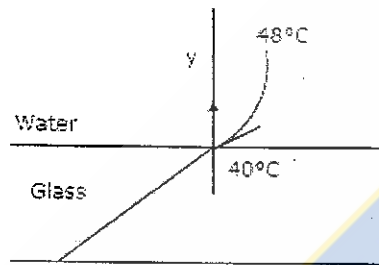

The value of the temperature gradient in the glass at the water-glass interface in K/m is:

- (a) -2×10^4 (b) 0.0 (c) 0.5×10^4 (d) 2×10^4

56. A p-v diagram has been obtained from a test on a reciprocating compressor. Which of the following represents that diagram?

(a)

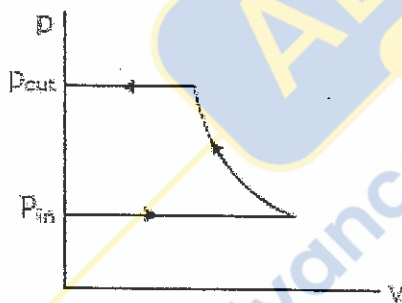

(b)

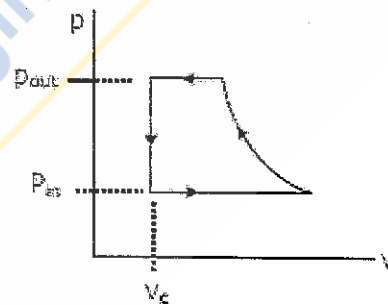

(c)

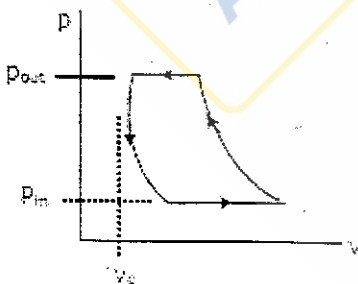

(d)

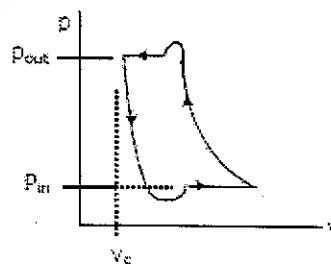

57. A small copper ball of 5 mm diameter at 500 K is dropped into an oil bath whose temperature is 300 K. the thermal conductivity of copper is 400 W/m-K, its density 9000 kg/m³ and its specific heat 385 J/kg-K, if the heat transfer coefficient is 250 W/m²-K and lumped analysis is assumed to be valid, the rate of fall of the temperature of the ball at the beginning of cooling will be, in K/s,
- (a) 8.7 (b) 13.9 (c) 17.3 (d) 27.7
58. A Carnot cycle operates between the temperatures limits of 300 K and 2000 K, and produces 600 kW of net power. The rate of entropy change of the working fluid during the heat addition process is:
- (a) 0 (b) 0.300 kW/K (c) 0.353 kW/K (d) 0.261 kW/K
59. Hot oil is cooled from 80 to 50°C in an oil cooler which uses air as the coolant. The air temperature rises from 30 to 40°C. The designer uses a LMTD value of 26°C. The type of heat exchanger is
- (a) Parallel flow (b) double pipe (c) counter flow (d) cross flow
60. Two bodies A and B having equal surface areas are maintained at 100 and 200. The thermal radiation emitted in a given time by A and B are in the ratio:
- (a) 1:1.15 (b) 1:2 (c) 1:4 (d) 1:16
61. Find the mass of the water vapour per cubic metre of air at temperature 300K and relative humidity 50%. The saturation vapour pressure at 300K is 3.6 kPa and gas constant $R = 8.3 \text{ JK}^{-1}\text{mol}^{-1}$
- (a) 15g (b) 130g (c) 31g (d) 13 g
62. For the three dimensional object shown in figure below, five faces are insulated. The sixth face (PQRS), which is not insulated, interacts thermally with the ambient, with a convective heat transfer coefficient of 10 W/m²-K. The ambient temperature is 30°C. Heat is uniformly generated inside the object at the rate of 100 W/m³. Assuming the face PQRS to be at uniform temperature, its steady state temperature is

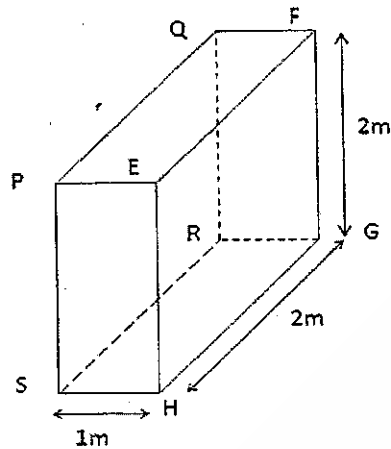

- (a) 10°C (b) 20°C (c) 30°C (d) 40°C

63. Two walls of thicknesses d_1 and d_2 and thermal conductivities k_1 and k_2 are in contact. In the steady state, if the temperatures at the outer surfaces are T_1 and T_2 , the temperature at the common wall is

- (a) $(k_1 T_1 d_2 + k_2 T_2 d_1) / (k_1 d_2 + k_2 d_1)$ (b) $(k_1 T_1 + k_2 T_2) / (d_1 + d_2)$
 (c) $[(k_1 d_1 + k_2 d_2) / (T_1 + T_2)] * T_1 T_2$ (d) $k_1 d_1 T_1 + k_2 d_2 T_2 / (k_1 d_1 + k_2 d_2)$

64. A Carnot cycle refrigerator operates between 250 K and 300 K. Its coefficient of performance (C.O.P.) is:

- (a) 6.0 (b) 5.0 (c) 1.2 (d) 0.8

65. A 3 m³ rigid tank contains nitrogen gas at 500 kPa and 300 K. Now heat is transferred to the nitrogen in the tank and the pressure of nitrogen rises to 800 kPa. The work done during this process is

- (a) 500 kJ (b) 1500 kJ (c) 0 kJ (d) 900 kJ

66. A solid cylinder (surface 2) is located at the centre of a hollow sphere (surface 1). The diameter of the sphere is 1m, while the cylinder has a diameter and length of 0.5 m each. The radiation configuration factor F_{11} is

- (a) 0.375 (b) 0.625 (c) 0.75 (d) 1.0

67. One kilogram of water at room temperature is brought into contact with a high temperature thermal reservoir. The entropy change of the universe is

- (a) equal to entropy change of the reservoir (b) equal to entropy change of water
(c) equal to zero (d) always positive

68. For specified limits for the maximum and minimum temperatures, the ideal cycle with the lowest thermal efficiency is:

- (a) Carnot (b) Stirling (c) Ericsson (d) Otto

69. A refrigerator removes heat from a refrigerated space at -5°C at a rate of 0.35 kJ/s and rejects it to an environment at 20°C . The minimum required power input is:

- (a) 30 W (b) 33 W (c) 56 W (d) 124 W

70. A heat pump is absorbing heat from the cold outdoors at 5°C and supplying heat to a house at 22°C at a rate of $18,000\text{ kJ/h}$. If the power consumed by the heat pump is 2.5 kW , the coefficient of performance (COP) of the heat pump is :

- (a) 0.5 (b) 1.0 (c) 2.0 (d) 5.0

71. . If the inner and outer walls of a hollow sphere having surface areas of A_1 and A_2 and inner and outer radii r_1 and r_2 are maintained at temperatures t_1 and t_2 , then rate of heat flow will be

- (a) $\frac{k}{\sqrt{A_1 A_2}} \frac{t_1 - t_2}{r_1 - r_2}$ (b) $k \sqrt{A_1 A_2} \frac{t_1 - t_2}{r_2 - r_1}$
(c) $4\pi k \frac{t_1 - t_2}{\sqrt{A_1 A_2}}$ (d) $4\pi k r_1 r_2 \frac{t_1 - t_2}{\sqrt{A_1 A_2}}$

72. Water is boiled at 1 atm pressure in a coffee maker equipped with an immersion-type electric heating element. The coffee maker initially contains 1 kg of water. Once boiling started, it is observed that half of the water in the coffee maker evaporated in 18 minutes. If the heat loss from the coffee maker is negligible, the power rating of the heating element is

- (a) 0.9 kW (b) 1.52 kW (c) 2.09 kW (d) 1.05 kW

73. Ductility of steel is reduced by

- (a) Hot rolling (b) Cold working (c) Piercing (d) Annealing

74. Machining of cast iron material is mostly performed

- (a) with flood coolant, (b) with mist coolant
(c) Dry (d) with high pressure coolant

75. A sine bar is used for the accurate measurement of

- (a) lengths (b) diameters (c) angles (d) depths

76. The process used to improve fatigue resistance of the metal by setting up compressive stresses in its surface, is known as

- (a) hot piercing (b) extrusion (c) cold peening (d) cold heading

77. The instrument which has all the features of try-square, bevel protractor, rule and scriber is

- (a) outside micrometer (b) inside micrometer
(c) depth gauge micrometer (d) combination set

78. Vector C is perpendicular to vectors A and B both, then:

- (a) $A \times B = C$ (b) $A \cdot B = C$ (c) $A \cdot [A \times C] = B$ (d) $B \times C = A$

79. An unbiased dice is tossed twice. Find the Probability of getting 4,5 or 6 on the first toss and a 1,2,3 or 4 on the second toss

- (a) $7/3$ (b) $18/23$ (c) $1/9$ (d) $1/3$

80. For the given characteristic matrix [A], determine the Eigen Values :-

$$[A] = \begin{bmatrix} 4 & 1 \\ 1 & 4 \end{bmatrix}$$

- (a) 5,3 (b) -5,-3 (c) -3,5 (d) 3,-5